

NOTES:  
1-ALL INTERCONNECTING WIRING WILL BE CUSTOMER'S RESPONSIBILITY.

**SAMPLE DRAWING**  
FOR QUOTATION  
PURPOSES ONLY

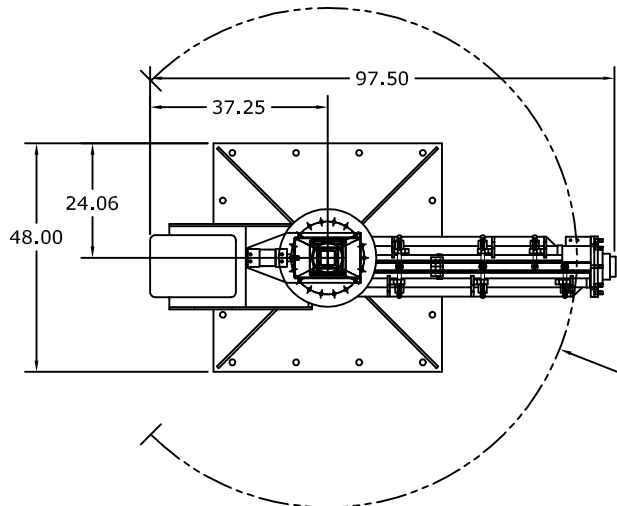

MAX. SWING  
RADIUS R52.45 WITH  
A MAX. ROTATION OF 270°

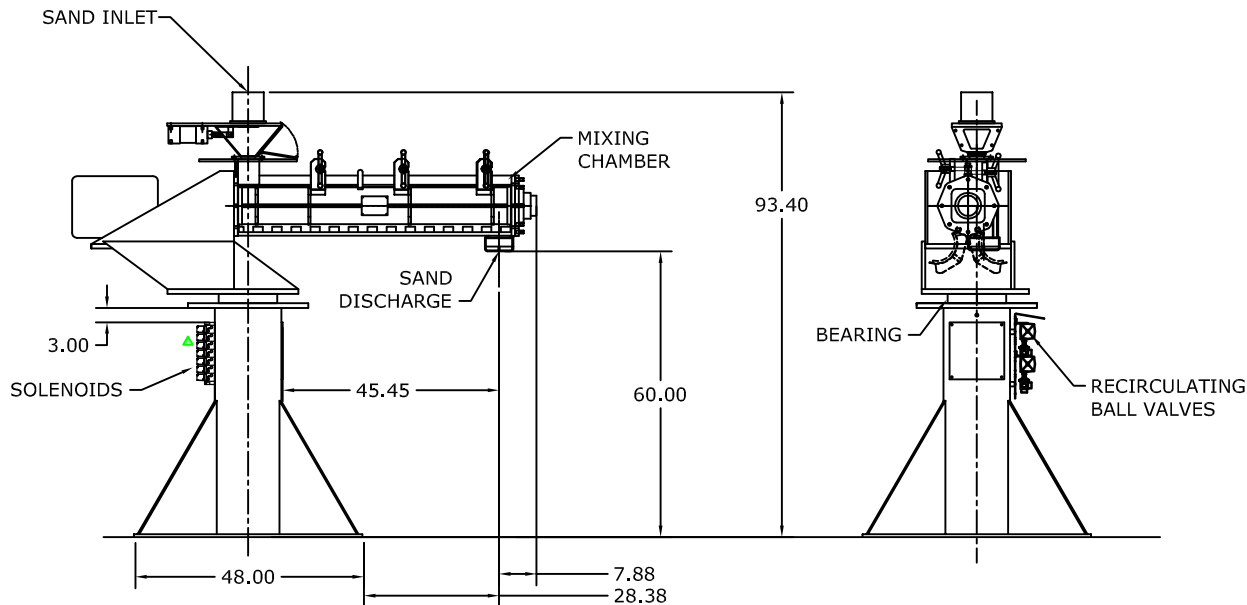

<p><b>CONFIDENTIAL</b></p> <p>THIS DOCUMENT, INCLUDING ALL INFORMATION HEREIN, IS THE EXCLUSIVE AND CONFIDENTIAL PROPERTY OF PALMER MANUFACTURING. THEREFORE THIS DOCUMENT IS NOT TO BE COPIED, REPRODUCED, OR DELIVERED TO OTHERS WITHOUT THE EXPRESS WRITTEN PERMISSION OF PALMER.</p> <p>NOTE: <b>REMOTE PUMPS AND CONTROLS NOT INCLUDED</b></p>			18 BECHTLE AVENUE SPRINGFIELD, OHIO 45504 U.S.A. (937) 323-6339 OR 1-800-457-5456
	SCALE: NONE	APPROVED BY:	DRAWN BY: SLW
	DATE: 3/15/11		
	TITLE: <b>M300XLD UNDER MOTOR SWIVEL MIXER</b>		
	PREVIOUS DWG. #: N/A	DWG. #: M11379	REV: -
		PG. #: 1 OF 2	